



**TRANE®**

# Multi-position, Upflow, Horizontal Left, or Horizontal Right, Modular Air Handlers

---

## **60 HZ Convertible Air Handlers**

Model: Series 2 Air Handlers 3-1/2 - 5 ton

GAT2A0B42S31SA

GAT2A0C48S41SA

GAT2A0C60S51SA

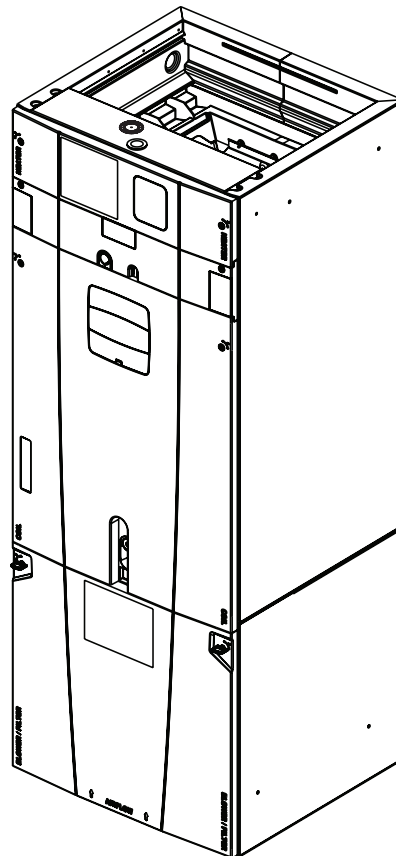

---

**PUB. NO. 22-1857-06**



## Features and Benefits

---

- Unique Cabinet Design
  - Double Wall Foamed and Formed Cabinet System
  - Water Proof Cabinet Design
  - R-4.2 Insulating Value (Avg. Insulating Value R-8.2)
  - Composite Foamed Cabinet Doors
  - Sweat Eliminating Cabinet Design
  - Loose Fiber Eliminating Cabinet Design
  - Smooth Cleanable Cabinet Design
  - 2% or Less air leakage
  - Precision Applied Durable Door Seals
  - Tool-free Fasteners on Blower/Filter Door
  - Modular Cabinet
- Multi-Position Upflow/ Horizontal Left / Horizontal Right
- Braze in Refrigerant Connection
- Primary/Secondary Condensate Connections
- Premarked Conduit Connection Locations
- Vortica Blower with Integrated Slide Deck for Easy Removal
- Polarized Plug connections on Blower
- Control Protection Pocket
- Aluminum Coil with Integrated Slide Deck for Easy Removal
- Slide in Electric Heaters
- Polarized Plug connections for Electric Heater
- Labeled Panels and connections
- 1-1/4" to 1" And 3/4" to 1/2" Conduit connection on Left, Right and Top
- Molded in 1" Standard Filter rail
- R-410A Thermal Expansion Valve (TXV)
- Convertible to R-22 using optional accessory TXV conversion kit.
- Low Voltage Terminal Connection Point
- Enhanced Coil Fin Patented
- Blow Through Design
- PSC 3 Speed Motor on 3.5 & 4 ton models
- Constant torque ECM Motor on 5 ton model
- Maximum Width of 23.5"
- Compact 20.8" depth with doors removed
- Integrated Horizontal Drain pans
- Single Color
- Fused 24V Power
- Safety Door Switch
- **5 year warranty**
- **10-year warranty registered**
- **Optional extended warranty available**



# Contents

---

<b>Features and Benefits</b>	<b>2</b>
Optional Equipment	4
<b>Unique Cabinet Design Features and Benefits</b>	<b>5</b>
<b>General Data</b>	<b>6</b>
GAT2A0B42S31SA	6
GAT2A0C48S41SA	6
GAT2A0C60S51SA	6
<b>Performance Data</b>	<b>7</b>
<b>Electrical Data</b>	<b>10</b>
<b>Wiring Diagrams</b>	<b>13</b>
<b>Field Wiring</b>	<b>15</b>
<b>Convertibility</b>	<b>17</b>
<b>Dimensions</b>	<b>18</b>



# Optional Equipment

## OPTIONAL EQUIPMENT FOR AIR HANDLERS

Accessory Number	Description	Fits Cabinet Size
BAYEAAC05BK1A	Electric Heater, 5kW, Breaker, 24V Control, 1 Ph	A to C
BAYEAAC05LG1A	Electric Heater, 5kW, Lugs, 24V Control, 1 Ph	A to C
BAYEAAC08BK1A	Electric Heater, 8kW, Breaker, 24V Control, 1 Ph	A to C
BAYEAAC08LG1A	Electric Heater, 8kW, Lugs, 24V Control, 1 Ph	A to C
BAYEAAC10BK1A	Electric Heater, 10kW, Breaker, 24V Control, 1 Ph	A to C
BAYEAAC10LG1A	Electric Heater, 10kW, Lugs, 24V Control, 1 Ph	A to C
BAYEAAC10LG3A	Electric Heater, 10kW, Lugs, 24V Control, 3 Ph	A to C
BAYEABC15BK1A	Electric Heater, 15kW, Breaker, 24V Control, 1 Ph	A to C
BAYEABC15LG3A	Electric Heater, 15kW, Lugs, 24V Control, 3 Ph	A to C
BAYEABC20BK1A	Electric Heater, 20kW, Breaker, 24V Control, 1 Ph	B to C
BAYEACC25BK1A	Electric Heater, 25kW, Breaker, 24V Control, 1 Ph	C
BAYSUPFLGBA	Supply Duct Flange B	B
BAYSUPFLGCA	Supply Duct Flange C	C
BAYRETLGB	Return Duct Flange B	B
BAYRETLGCA	Return Duct Flange C	C
TASB215SB	Plenum Stand B with integrated sound baffle	B
TASB235SB	Plenum Stand C with integrated sound baffle	C
BAYSRKIT100A	Side Return Kit	A to C
BAYICSKIT01A	Internal Condensate Switch Kit	A to C
BAYHHKIT001A	Horizontal Hanger Kit	A to C
BAYUVCLK001A	UVC Lights	A to C
BAYLVKIT100A	Low Voltage Conduit Entry Kit	A to C
BAYATXV4248A	R-22 TXV conversion kit - 3-1/2 & 4 ton	B to C
BAYATXV6060A	R-22 TXV conversion kit - 5 ton	C



# Unique Cabinet Design Features and Benefits

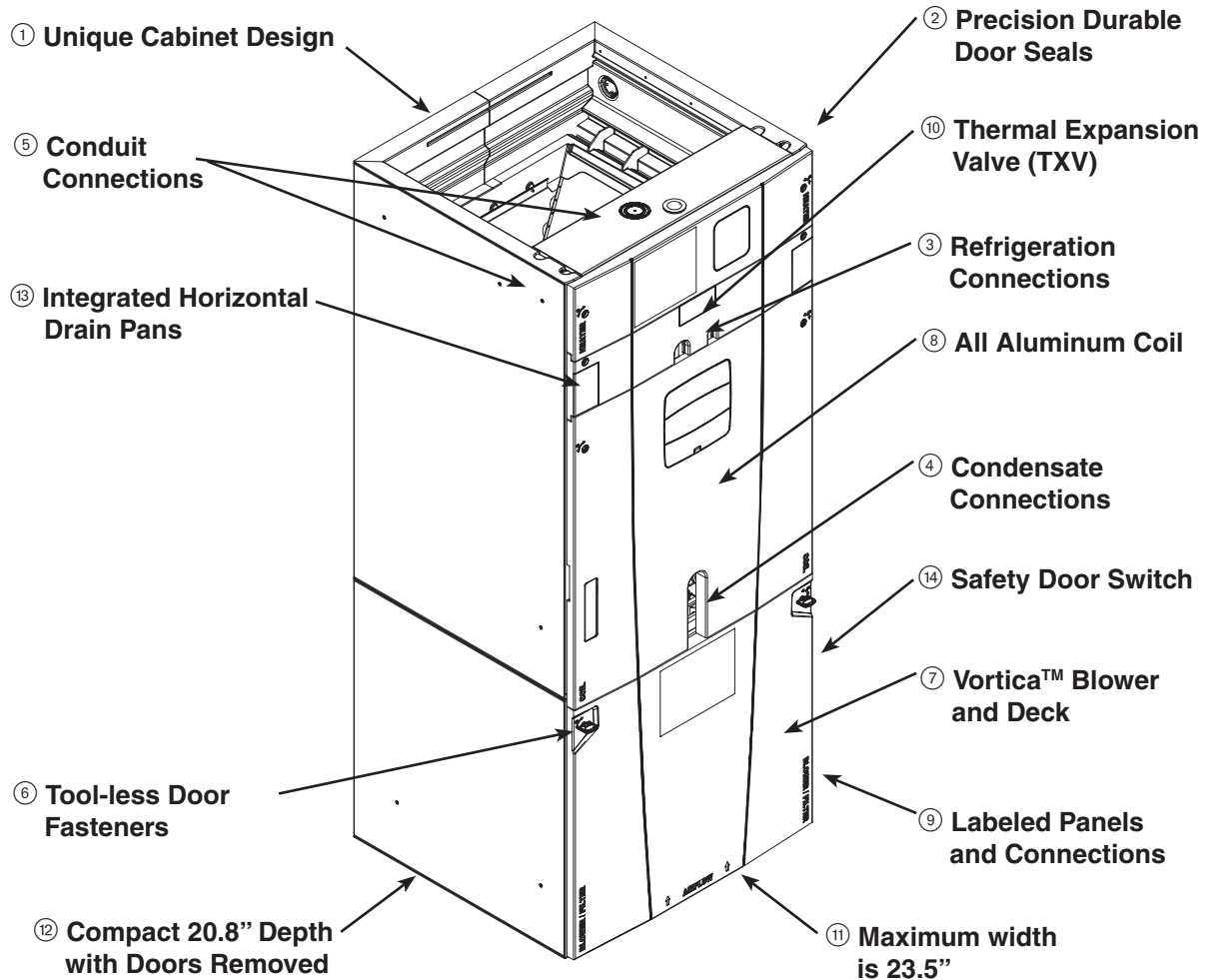

- ① **Unique Cabinet Design**
  - Double wall foamed cabinet system
  - Waterproof Cabinet Design
  - R-4.2 Insulating Value (Avg Insulating Value R-8.2)
  - Composite Foamed Cabinet Doors
  - Sweat Eliminating Cabinet Design
  - Loose Fiber Eliminating Design
  - Smooth Cleanable Cabinet Design
- ② **Precision Durable Door Seals**
- ③ **Refrigeration Connections**
- ④ **Condensate Connections**
- ⑤ **Premarked Conduit Connection Locations** - Conduit Connections on Left, Right, and Top
- ⑥ **Tool-less Door Fasteners**
- ⑦ **Vortica™ Blower and Deck** - Polarized Plug on Blower
- ⑧ **All Aluminum Coil**
  - Integrated Slide Deck for Easy Removal
  - Polarized Plug connections on Coil EEV
  - Patented Enhanced Coil Fin
- ⑨ **Labeled Panels and Connections**
- ⑩ **R-410A Thermal Expansion Valve (TXV)**
- ⑪ **Maximum width is 23.5"**
- ⑫ **Compact 20.8" Depth with Doors Removed**
- ⑬ **Integrated Horizontal Drain Pans**
- ⑭ **Safety Door Switch** - Fused 24V Power
- ⑮ **Modular Cabinet**

**TRANE®**

# General Data

## PRODUCT SPECIFICATIONS

MODEL	GAT2A0B42S31SA	GAT2A0C48S41SA	GAT2A0C60S51SA
<b>RATED VOLTS/PH/HZ.</b>	208-230/1/60	208-230/1/60	208-230/1/60
<b>RATINGS</b> ①	See O.D. Specifications	See O.D. Specifications	See O.D. Specifications
<b>INDOOR COIL — Type</b>	Plate Fin	Plate Fin	Plate Fin
Rows — F.P.I.	3 - 14	3 - 14	4 - 14
Face Area (sq. ft.)	5.04	5.50	5.50
Tube Size (in.)	3/8	3/8	3/8
Refrigerant Control	TXV	TXV	TXV
Drain Conn. Size (in.) ②	3/4 NPT	3/4 NPT	3/4 NPT
<b>DUCT CONNECTIONS</b>	See Outline Drawing	See Outline Drawing	See Outline Drawing
<b>INDOOR FAN — Type</b>	Centrifugal	Centrifugal	Centrifugal
Diameter-Width (In.)	10 X 10	11 X 10	11 X 10
No. Used	1	1	1
Drive - No. Speeds	Direct - 3	Direct - 3	Direct - 5 ③
CFM vs. in. w.g.	See Fan Performance Table	See Fan Performance Table	See Fan Performance Table
No. Motors — H.P.	1 - 1/2	1 - 1/2	1 - 1
Motor Speed RPM	1075	1075	1050
Volts/Ph/Hz	208-230/1/60	208-230/1/60	208-230/1/60
F.L. Amps - L.R. Amps	2.7 - 5.0	3.1 - 5.5	7.6 - n/a
<b>FILTER</b>			
Filter Furnished?	No	No	No
Type Recommended	Throwaway	Throwaway	Throwaway
No.-Size-Thickness	1 - 20 X 20 - 1 in.	1 - 20 X 22 - 1 in.	1 - 20 X 22 - 1 in.
<b>REFRIGERANT</b>	<b>R-410A</b> ④	<b>R-410A</b> ④	<b>R-410A</b> ⑤
Ref. Line Connections	Brazed	Brazed	Brazed
Coupling or Conn. Size — in. Gas	7/8	7/8	7/8
Coupling or Conn. Size — in. Liq.	3/8	3/8	3/8
<b>DIMENSIONS</b>	H x W x D	H x W x D	H x W x D
Crated (In.)	56.8 x 23.5 x 24.5	58 x 25.5 x 24.5	62.8 x 25.5 x 24.5
Uncrated	55.7 x 21.3 x 21.8	56.9 x 23.5 x 21.8	61.7 x 23.5 x 21.8
<b>WEIGHT</b>			
Shipping (Lbs.)/Net (Lbs.)	144/133	155/143	171/159

① These Air Handlers are AHRI certified with various Split System Air Conditioners and Heat Pumps (AHRI STANDARD 210/240). Refer to the Split System Outdoor Unit Product Data Guides for performance data.

② 3/4" Male Plastic Pipe (Ref.: ASTM 1785-76)

③ Constant torque Motor

④ R-22 requires TXV change. Use R-22 TXV conversion kit BAYATXV4248A.

⑤ R-22 requires TXV change. Use R-22 TXV conversion kit BAYATXV6060A.



# General Data

**GAT2A0B42 AIRFLOW PERFORMANCE TABLE**

AIRFLOW PERFORMANCE						
GAT2A0B42S31SA						
EXTERNAL STATIC (in w.g)	AIRFLOW (CFM)					
	Speed Taps - 230 VOLTS			Speed Taps - 208 VOLTS		
	3	2 †	1	3	2 †	1
0	1646	1495	1358	1522	1298	1138
0.1	1599	1464	1335	1489	1285	1137
0.2	1546	1421	1313	1449	1260	1120
0.3	1488	1380	1280	1401	1233	1099
0.4	1425	1329	1233	1348	1193	1065
0.5	1353	1264	1178	1281	1140	1023
0.6	1259	1182	1108	1202	1075	958
0.7	1145	1081	995	1102	965	868
0.8	982	909	839	926	817	753
0.9	788	759	731	761	713	N/A
1.0	563	N/A	N/A	538	N/A	N/A

NOTES:  
 1. Values are with wet coil and without filters.  
 2. Contact your particular filter manufacturer for pressure drop data.  
 3. Electric heater pressure drop is negligible and is included within the airflow data.  
 4. † Factory Setting

GAT2A0B42S31SA MINIMUM HEATER AIRFLOW CFM		
Heater	Minimum Air Speed Tap	
	With Heat Pump	Without Heat Pump
BAYEAAC05BK1AA BAYEAAC05LG1AA	Tap 1	Tap 1
BAYEAAC08BK1AA BAYEAAC08LG1AA	Tap 1	Tap 1
BAYEAAC10BK1AA BAYEAAC10LG1AA	Tap 1	Tap 1
BAYEAAC10LG3AA	Tap 1	Tap 1
BAYEABC15BK1AA	Tap 1	Tap 1
BAYEABC15LG3AA	Tap 3	Tap 1
BAYEABC20BK1AA	Tap 3	Tap 1

SEE AIR HANDLER NAMEPLATE OR PRODUCT DATA FOR EXCEPTIONS

**Note:** Heating and cooling speeds are the same, factory set at Speed Tap #2.



**TRANE®**

# Performance Data

**GAT2A0C48 AIRFLOW PERFORMANCE TABLE**

AIRFLOW PERFORMANCE						
GAT2A0C48S41SA						
EXTERNAL STATIC (in w.g)	AIRFLOW (CFM)					
	Speed Taps - 230 VOLTS			Speed Taps - 208 VOLTS		
	3	2 †	1	3	2 †	1
0	1904	1711	1541	1652	1455	1305
0.1	1881	1687	1529	1640	1450	1288
0.2	1844	1666	1511	1619	1425	1271
0.3	1806	1637	1485	1592	1410	1249
0.4	1766	1602	1454	1559	1381	1231
0.5	1716	1560	1420	1524	1351	1198
0.6	1659	1513	1380	1484	1321	1165
0.7	1594	1458	1333	1434	1283	1127
0.8	1525	1395	1277	1376	1229	1067
0.9	1442	1310	1194	1304	1149	N/A
1.0	1345	N/A	N/A	1194	N/A	N/A

**NOTES:**  
 1. Values are with wet coil and without filters.  
 2. Contact your particular filter manufacturer for pressure drop data.  
 3. Electric heater pressure drop is negligible and is included within the airflow data.  
 4. † Factory Setting

GAT2A0C48S41SA MINIMUM HEATER AIRFLOW CFM		
Heater	Minimum Air Speed Tap	
	With Heat Pump	Without Heat Pump
BAYEAAC05BK1AA BAYEAAC05LG1AA	Tap 1	Tap 1
BAYEAAC08BK1AA BAYEAAC08LG1AA	Tap 1	Tap 1
BAYEAAC10BK1AA BAYEAAC10LG1AA	Tap 1	Tap 1
BAYEAAC10LG3AA	Tap 1 ②	Tap 1 ②
BAYEABC15BK1AA	Tap 1	Tap 1
BAYEABC15LG3AA	Tap 1	Tap 1
BAYEABC20BK1AA	Tap 1	Tap 1
BAYEACC25BK1AA	Tap 3	Tap 2 ①

SEE AIR HANDLER NAMEPLATE OR PRODUCT DATA FOR EXCEPTIONS  
 ① Not qualified for 208V  
 ② Not qualified for 208V in upflow installations

**Note:** Heating and cooling speeds are the same, factory set at Speed Tap #2.





# Performance Data

**GAT2A0C60 AIRFLOW PERFORMANCE TABLE**

AIRFLOW PERFORMANCE										
GAT2A0C60S51SA										
EXTERNAL STATIC (in w.g)	AIRFLOW (CFM)									
	Speed Taps - 230 VOLTS					Speed Taps - 208 VOLTS				
	5	4 †	3	2	1	5	4 †	3	2	1
0	2169	1956	1874	1739	1633	2165	2033	1871	1736	1629
0.1	2161	1916	1839	1696	1588	2155	1990	1833	1690	1582
0.2	2130	1889	1803	1667	1554	2121	1961	1795	1659	1545
0.3	2102	1850	1774	1628	1523	2090	1919	1763	1617	1511
0.4	2066	1818	1741	1596	1491	2052	1884	1727	1582	1477
0.5	2015	1785	1707	1564	1457	1998	1848	1690	1547	1440
0.6	1959	1754	1673	1520	1408	1939	1814	1653	1500	1389
0.7	1888	1716	1638	1477	1372	1880	1774	1615	1455	1349
0.8	1811	1680	1605	1440	1323	1820	1735	1580	1415	1298
0.9	1750	1628	1561	1403	1291	1770	1680	1533	1376	1263
1.0	1680	1604	1533	1368	1256	1725	1654	1503	1337	1226

**NOTES:**

1. Values are with wet coil and without filters.
2. Contact your particular filter manufacturer for pressure drop data.
3. Electric heater pressure drop is negligible and is included within the airflow data.
4. † Factory Setting

GAT2A0C60S51SA MINIMUM HEATER AIRFLOW CFM		
Heater	Minimum Air Speed Tap	
	With Heat Pump	Without Heat Pump
BAYEAAC05BK1AA BAYEAAC05LG1AA	Tap 2	Tap 2
BAYEAAC08BK1AA BAYEAAC08LG1AA	Tap 3	Tap 2
BAYEAAC10BK1AA BAYEAAC10LG1AA	Tap 3	Tap 2
BAYEAAC10LG3AA	Tap 1	Tap 1
BAYEABC15BK1AA	Tap 4	Tap 3
BAYEABC15LG3AA	Tap 1	Tap 1
BAYEABC20BK1AA	Tap 4	Tap 3
BAYEACC25BK1AA	Tap 5	Tap 4

SEE AIR HANDLER NAMEPLATE OR PRODUCT DATA FOR EXCEPTIONS

**Note:** Heating and cooling speeds are the same, factory set at Speed Tap #4 for the CTM motor.



**TRANE®**

# Performance Data

WIRING DATA											
GAT2A0B42S31SA											
Heater Model No.	No. of Circuits	240 VOLT					208 VOLT				
		Capacity		Heater Amps per Circuit	Minimum Circuit Ampacity	Maximum Overload Protection	Capacity		Heater Amps per Circuit	Minimum Circuit Ampacity	Maximum Overload Protection
		kW	BTUH				kW	BTUH			
No Heater	-	-	-	2.7**	3	15	-	-	2.7**	3	15
BAYEAAC05++1	1	4.80	16400	20	28	30	3.60	12300	17.3	25	25
BAYEAAC08++1	1	7.68	26200	32	43	45	5.76	19700	27.7	38	40
BAYEAAC10++1	1	9.60	32800	40	53	60	7.20	24600	34.6	47	50
BAYEAAC10LG3	1 - 3PH	9.60	32800	23.1	32	35	7.20	24600	20.0	28	30
BAYEABC15LG3	1 - 3PH	14.40	49200	34.6	46	50	10.80	36900	30.0	40	40
BAYEABC15++1	2										
circuit 1		9.60	32800	40	53	60	7.20	24600	34.6	47	50
circuit 2		4.80	16400	20	25	25	3.60	12300	17.3	22	25
BAYEABC20++1	2										
circuit 1		9.60	32800	40	53	60	7.20	24600	34.6	53	60
circuit 2		9.60	32800	40	50	50	7.20	24600	34.6	43	45

Note: \*\* Motor Amps



# Performance Data

WIRING DATA											
GAT2A0C48S41SA											
Heater Model No.	No. of Circuits	240 VOLT					208 VOLT				
		Capacity		Heater Amps per Circuit	Minimum Circuit Ampacity	Maximum Overload Protection	Capacity		Heater Amps per Circuit	Minimum Circuit Ampacity	Maximum Overload Protection
		kW	BTUH				kW	BTUH			
No Heater	-	-	-	3.1**	4	15	-	-	3.1**	4	15
BAYE AAC05++1	1	4.80	16400	20.0	29	30	3.60	12300	17.3	26	30
BAYE AAC08++1	1	7.68	26200	32.0	44	45	5.76	19700	27.7	38	40
BAYE AAC10++1	1	9.60	32800	40.0	54	60	7.20	24600	34.6	47	50
BAYE AAC10LG3 ②	1-3PH	9.60	32800	23.1	32	35	7.20	24600	20.0	28	30
BAYE ABC15LG3	1-3PH	14.40	49200	34.6	47	50	10.80	36900	30.0	41	45
BAYE ABC15++1	2										
circuit 1		9.60	32800	40.0	54	60	7.20	24600	34.6	47	50
circuit 2		4.80	16400	20.0	25	25	3.60	12300	17.3	22	25
BAYE ABC20++1	2										
circuit 1		9.60	32800	40.0	54	60	7.20	24600	34.6	53	60
circuit 2		9.60	32800	40.0	50	50	7.20	24600	34.6	43	45
BAYE ACC25++1 ①	3										
circuit 1		9.60	32800	40.0	54	60	7.20	24600	34.6	47	50
circuit 2		9.60	32800	40.0	50	50	7.20	24600	34.6	43	45
circuit 3		4.80	16400	20.0	25	25	3.60	12300	17.3	22	25

Note: \*\* Motor Amps  
 ① Not qualified for 208V without heat pump.  
 ② Not qualified for 208V in upflow installations.



**TRANE®**

# Performance Data

WIRING DATA											
GAT2A0C60S51SA											
Heater Model No.	No. of Circuits	240 VOLT					208 VOLT				
		Capacity		Heater Amps per Circuit	Minimum Circuit Ampacity	Maximum Overload Protection	Capacity		Heater Amps per Circuit	Minimum Circuit Ampacity	Maximum Overload Protection
		kW	BTUH				kW	BTUH			
No Heater	-	-	-	7.6**	10	15	-	-	7.6**	10	15
BAYEAAC05++1	1	4.80	16400	20.0	35	35	3.60	12300	17.3	31	35
BAYEAAC08++1	1	7.68	26200	32.0	50	50	5.76	19700	27.7	44	45
BAYEAAC10++1	1	9.60	32800	40.0	60	60	7.20	24600	34.6	53	60
BAYEAAC10LG3	1 - 3PH	9.60	32800	23.1	37	40	7.20	24600	20.0	34	35
BAYEABC15LG3	1 - 3PH	14.40	49200	34.6	52	60	10.80	36900	30.0	46	50
BAYEABC15++1	2										
circuit 1		9.60	32800	40.0	60	60	7.20	24600	34.6	53	60
circuit 2		4.80	16400	20.0	25	25	3.60	12300	17.3	22	25
BAYEABC20++1	2										
circuit 1		9.60	32800	40.0	60	60	7.20	24600	34.6	53	60
circuit 2		9.60	32800	40.0	50	50	7.20	24600	34.6	43	45
BAYEACC25++1	3										
circuit 1		9.60	32800	40.0	60	60	7.20	24600	34.6	53	60
circuit 2		9.60	32800	40.0	50	50	7.20	24600	34.6	43	45
circuit 3		4.80	16400	20.0	25	25	3.60	12300	17.3	22	25

Note: \*\* Motor Amps

## DISTANCE FROM BELLY BAND TO SHAFT FACE OF MOTOR FOR MINIMUM VIBRATION

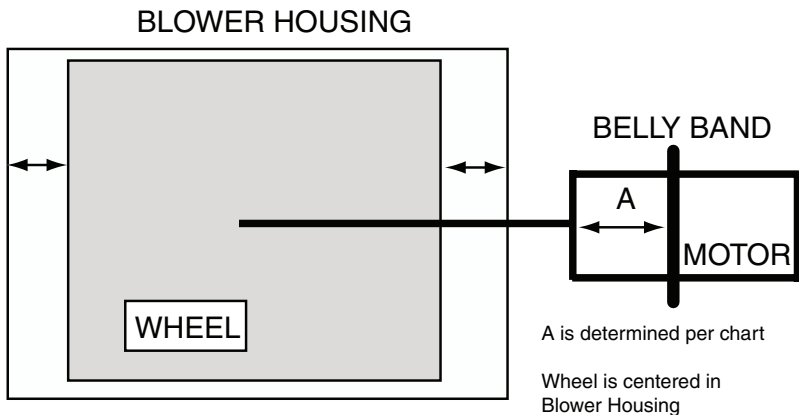

MODEL	DIM "A"
GAT2A0B42S31SA	3
GAT2A0C48S41SA	2-13/16
GAT2A0C60S51SA	2-1/4

# WIRING DIAGRAM FOR GAT2A0B42 AND GAT2A0C48 AIR HANDLERS

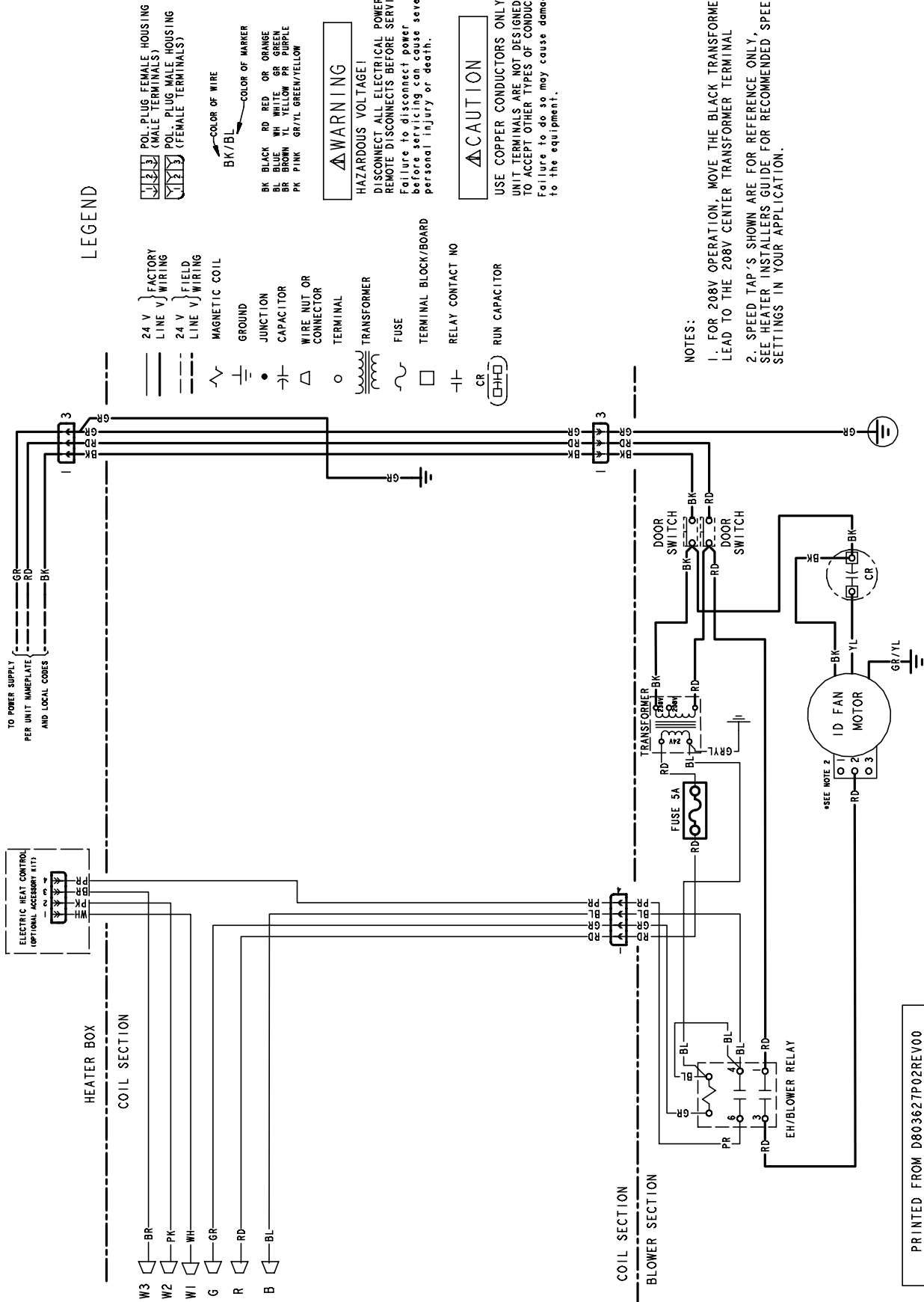

# WIRING DIAGRAM FOR GAT2A0C60 AIR HANDLERS

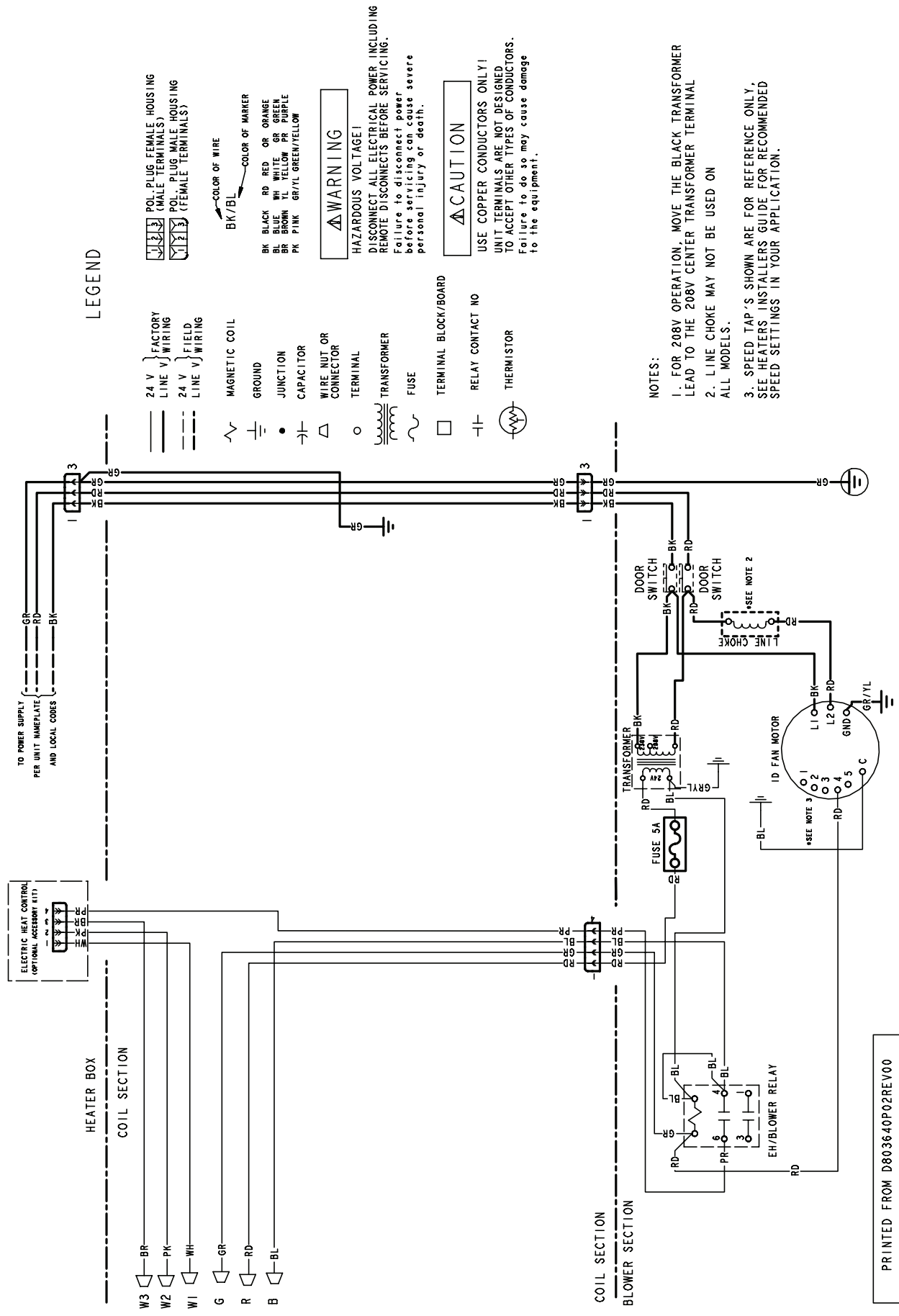

## LEGEND

- 24 V } FACTORY LINE V WIRING
- 24 V } FIELD WIRING
- MAGNETIC COIL
- GROUND
- JUNCTION
- CAPACITOR
- WIRE NUT OR CONNECTOR
- TERMINAL
- TRANSFORMER
- FUSE
- TERMINAL BLOCK/BOARD
- RELAY CONTACT NO
- THERMISTOR
- POL. PLUG FEMALE HOUSING (MALE TERMINALS)
- POL. PLUG MALE HOUSING (FEMALE TERMINALS)
- COLOR OF WIRE
- COLOR OF MARKER
- BK BLACK RD RED OR ORANGE
- BL BLUE WH WHITE GR GREEN
- BR BROWN YL YELLOW PR PURPLE
- PK PINK GR/YL GREEN/YELLOW

**WARNING**  
HAZARDOUS VOLTAGE!  
DISCONNECT ALL ELECTRICAL POWER, INCLUDING REMOTE DISCONNECTS BEFORE SERVICING.  
Failure to disconnect power before servicing can cause severe personal injury or death.

**CAUTION**  
USE COPPER CONDUCTORS ONLY!  
UNIT TERMINALS ARE NOT DESIGNED TO ACCEPT OTHER TYPES OF CONDUCTORS.  
Failure to do so may cause damage to the equipment.

## NOTES:

- FOR 208V OPERATION, MOVE THE BLACK TRANSFORMER LEAD TO THE 208V CENTER TRANSFORMER TERMINAL ALL MODELS.
- LINE CHOKE MAY NOT BE USED ON ALL MODELS.
- SPEED TAP'S SHOWN ARE FOR REFERENCE ONLY. SEE HEATERS INSTALLERS GUIDE FOR RECOMMENDED SPEED SETTINGS IN YOUR APPLICATION.

# Field Wiring

## GAT2 AIR HANDLERS WITH SINGLE SPEED COOLING

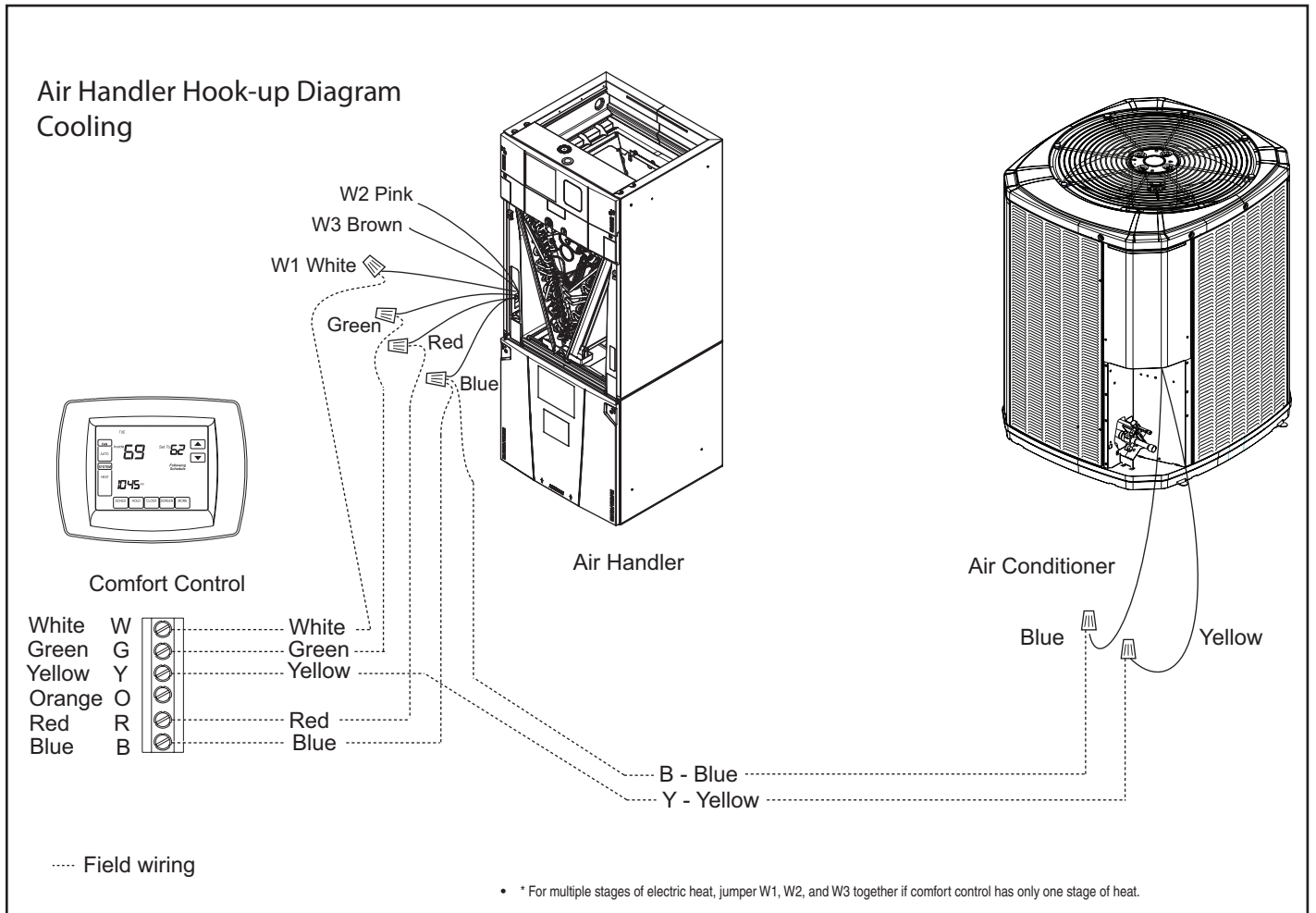



**TRANE®**

# Field Wiring

## GAT2 AIR HANDLERS WITH SINGLE SPEED HEAT PUMP

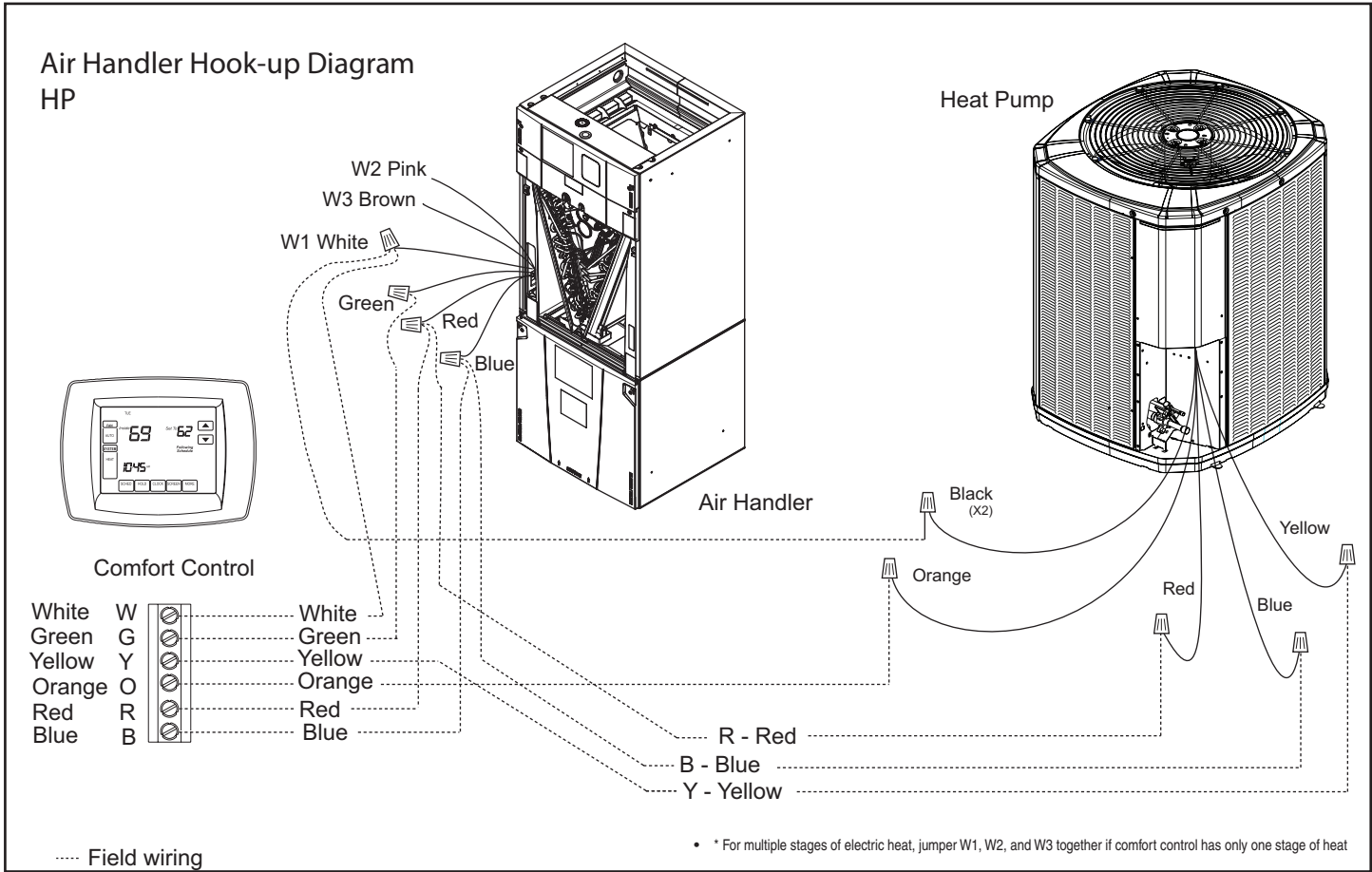



# GAT2 Convertibility

\* Note: No internal modifications required for any position.

① Badge rotation will keep brand in correct position

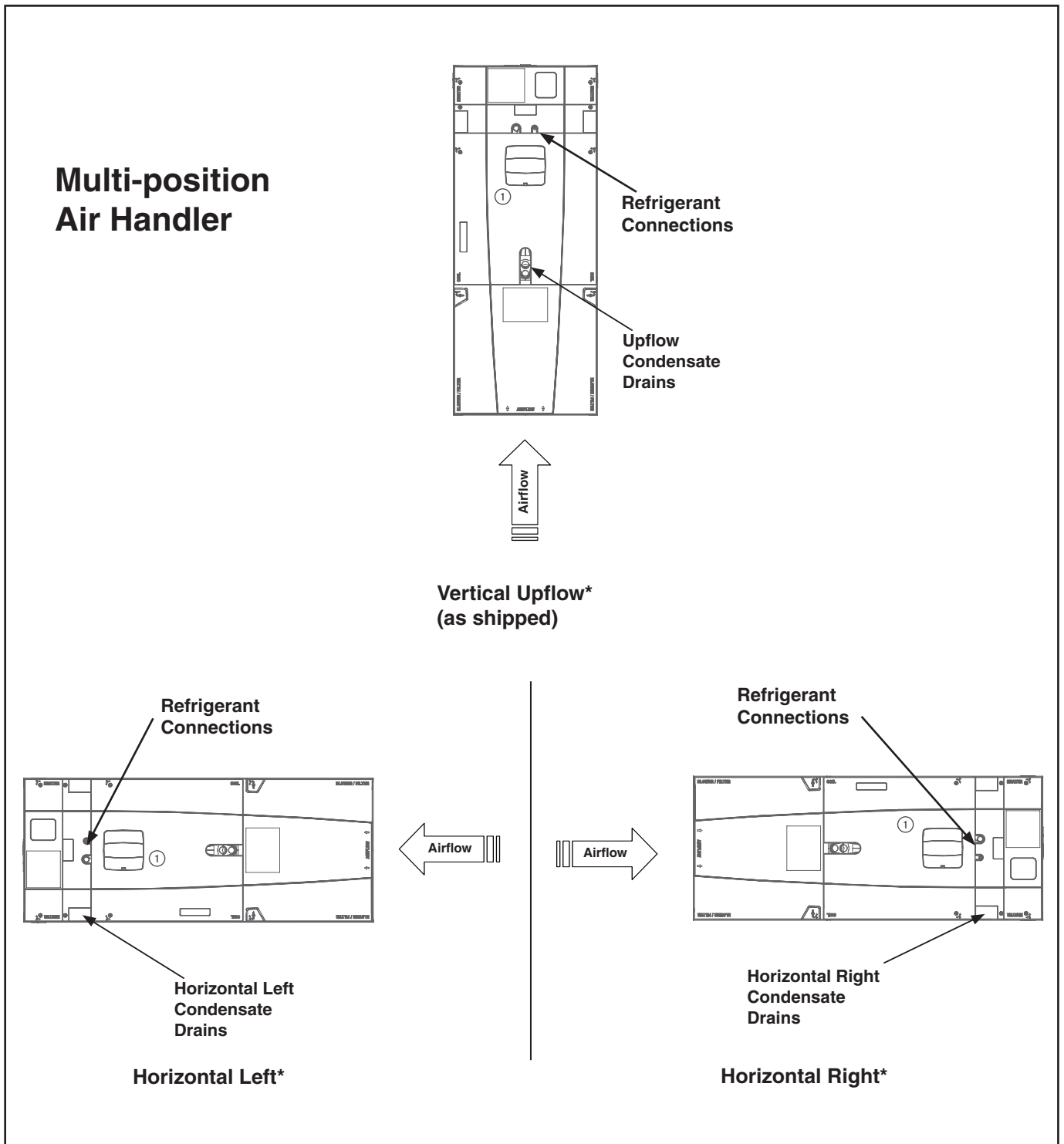



# Dimensions

GAT2 AIR HANDLER DIMENSIONAL DATA

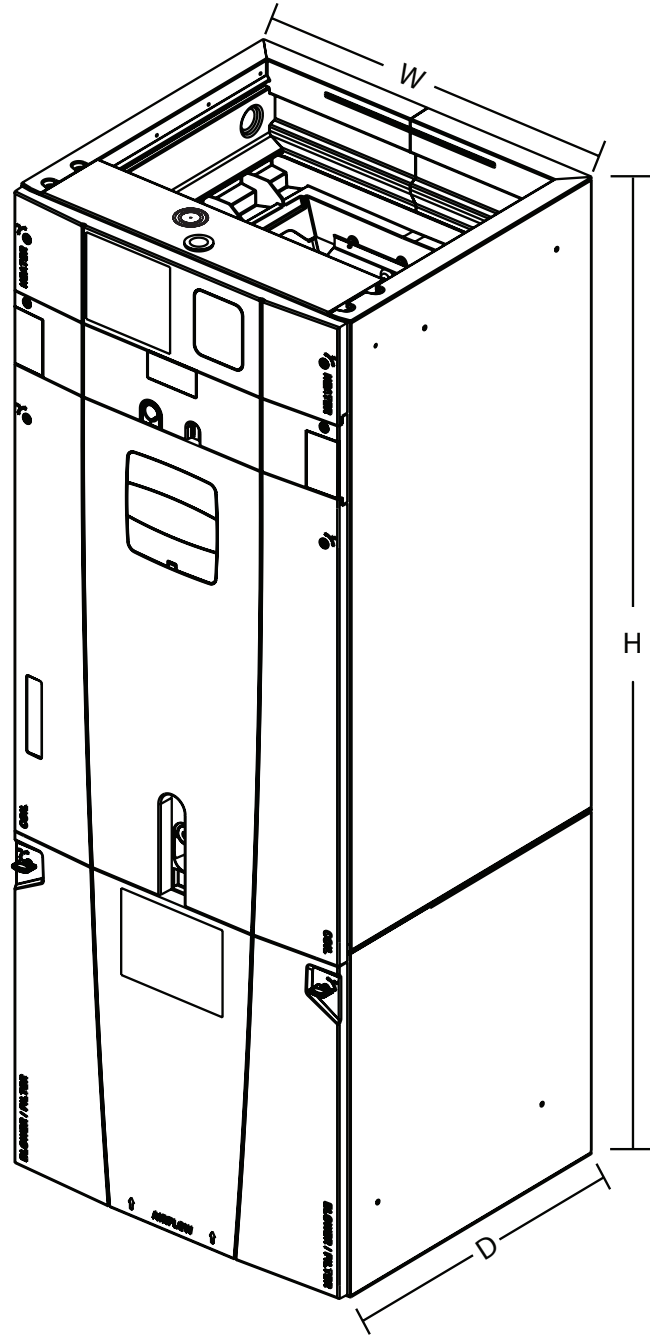

Model No.	H	W	D
GAT2A0B42	55.7	21.3	21.75
GAT2A0C48	56.9	23.5	21.75
GAT2A0C60	61.7	23.5	21.75

GAT2 AIR HANDLERS ARE ALL TWO  
PIECE CABINETS.

# GAT2 OUTLINE DRAWING

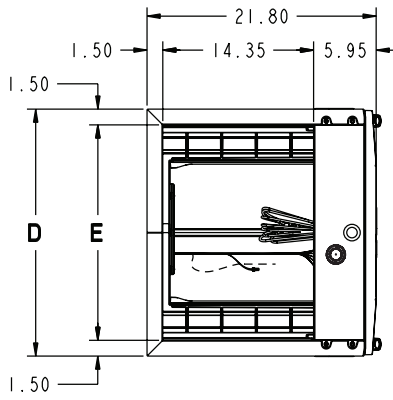

MINIMUM UNIT CLEARANCE TABLE		
	TO COMBUSTIBLE MATERIAL (REQUIRED)	SERVICE CLEARANCE (RECOMMENDED)
SIDES	0"	2"
FRONT	0"	21"
BACK	0"	0"
INLET DUCT	0"	
OUTLET DUCT	0"	

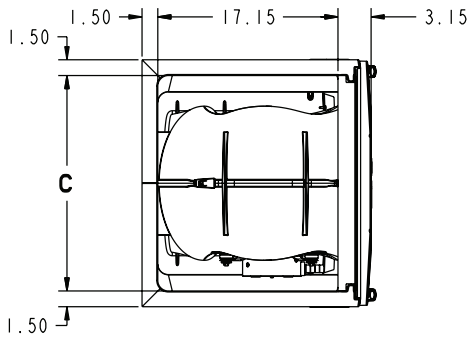
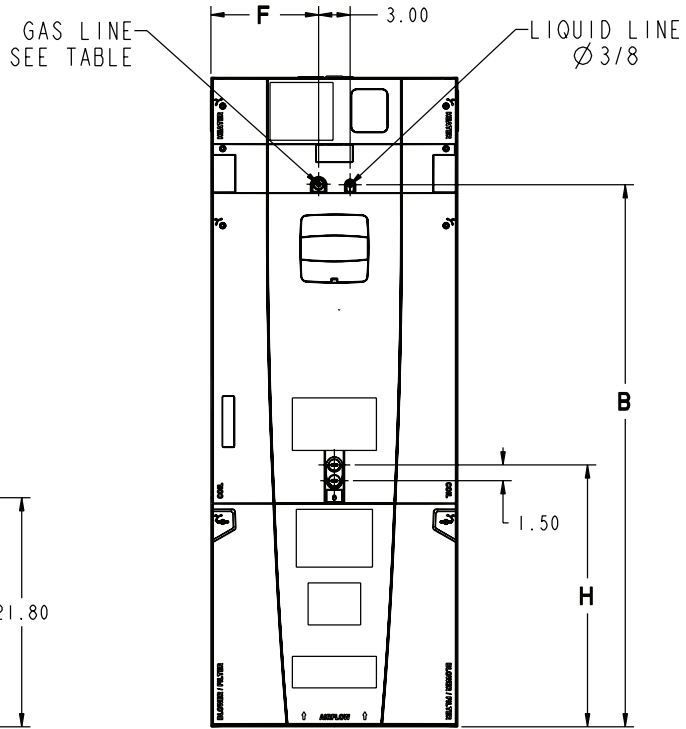
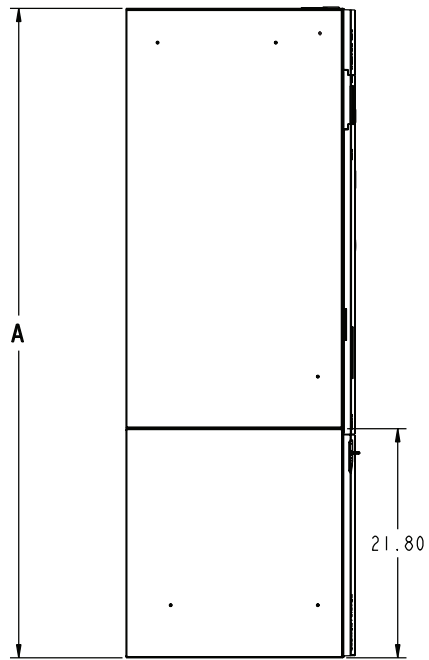

MODEL NO.	A	B	C	D	E	F	H	FLOW CONTROL	GAS LINE BRAZE
GAT2A0B42	55.7	45.5	18.4	21.3	18.4	9.2	24.8	TXV	7/8
GAT2A0C48	56.9	46.7	20.5	23.5	20.5	10.3	24.2	TXV	7/8
GAT2A0C60	61.7	51.5	20.5	23.5	20.5	10.3	27.0	TXV	7/8

